

# FSHP-1000-6000-30-N

## High Pass Filter Specifications

Electrical Specifications		
1	Pass Band Frequency	1000~6000MHz
2	Insertion Loss	≤1.6dB
3	VSWR	≤1.50:1
4	Isolation	≥30dB@DC~930MHz
5	Power Handling	50W
Environmental Characteristics		
1	Operating Temperature	-40°C~+70°C
2	Environmental Class	Indoor
Mechanical Characteristics		
1	Connectors	N-Female
2	Surface Finishing	Silver Plating
3	Dimensions <sup>1</sup>	50*20*20 mm [1.97*0.79*0.79 in]

### Outline Drawing

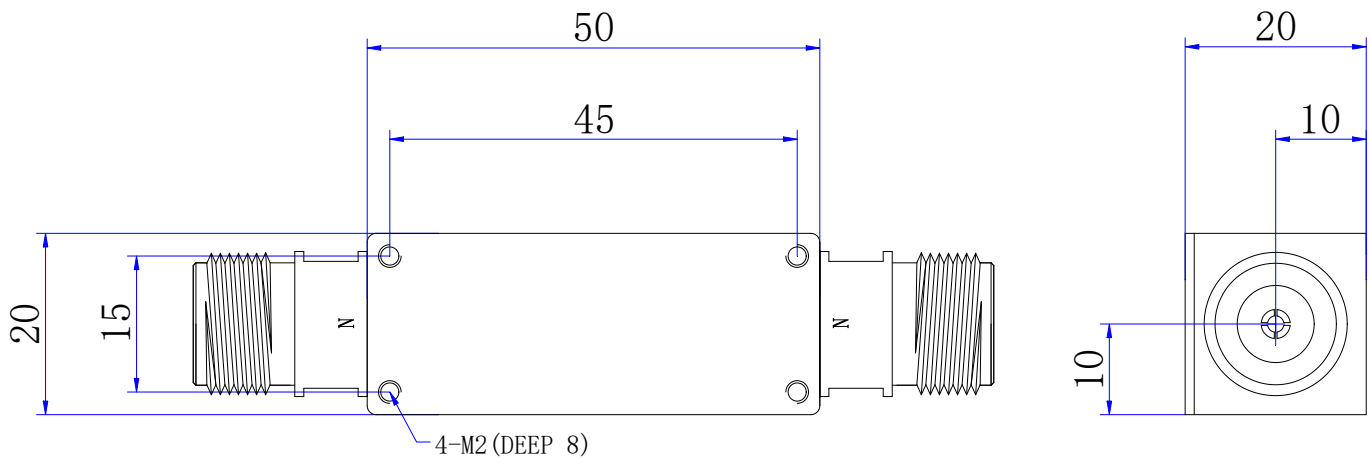

Units: mm/[inch], Tolerance: ±0.5mm, Mounting Hole Tolerance: ±0.2mm

Note 1: Excluding Connectors